



SERVICE BULLETIN

Service Bulletin #: SB03

Title: Engine Instrument Software Update.

1. Planning Information

A. Effectivity/Compatibility

This Service Bulletin applies to all Avidyne EX5000C's, with the following software part number:

Part Number	Rev.	Software Level
530-00112-000	00	Release 5.2.0
530-00112-000	01	Release 5.2.1
530-00112-000	02	Release 5.2.2

The software part number, revision and software level are displayed on the EX5000C screen during the startup sequence, above the text "Initializing-Please Wait...".

B. Concurrent Requirements

None

C. Reason

A change in the software has been made to provide Engine Instrument display functionality

D. Description

This modification consists of:

- 1) Removing the current compact flash and replacing it with the upgraded compact flash, while the EX5000C is on the bench.
- 2) Application of an additional label that contains additional TSO references.

E. Compliance

This is an optional functionality upgrade that may be installed at the operator's convenience. The installation should reference the appropriate installation of the EX5000C engine instrument per STC SA00143BO and SA00152BO.

F. Approval

No portion of this service bulletin is FAA approved.



SERVICE BULLETIN

G. Manpower

Removal and replacement of the compact flash and should take approximately 10 minutes.
Placement of an the additional label should take approximately 30 seconds.

H. Weight and Balance

No change.

I. Electrical Load Data

Not changed.

J. Software Accomplishment

See paragraph 1C Reasons for change.

K. Reference

Installation manual p/n 600-00073

L. Publications Affected

None

2. Material - Cost and Availability

Cost: Contact Avidyne at 1-888-AVIDYNE.

Availability: Contact Avidyne at 1-888-AVIDYNE and ask for p/n 530-00117-000 Rev 00 compact flash.

This modification may be performed by an authorized Cirrus Service Center, or an Avidyne approved service location subject to current terms and conditions.

3. Accomplishment Instructions

A. Removal of the EX5000C from the aircraft.

1. Access Maintenance Setup pages and record setup values.
2. Remove radio rack interior trim cap.
3. Loosen the 4 Dzus fasteners that hold the unit to the cockpit panel.
4. Pull the unit out approximately 8".
5. Disconnect the cable.



SERVICE BULLETIN

B. Compact Flash Removal

This procedure should be performed on the bench. Ensure NO power is applied to the unit. Refer to Figure 1.

1. Remove the Flash cover by unscrewing the 6 nuts and lifting the cover off the posts.
2. Remove the 530-00112-000 Rev XX (See effectivity/compatibility) compact flash by pulling it from the connector and sliding it out (as shown in Figure 1).
3. Record the serial number of the EX5000C on the removed compact flash and return it to Avidyne Corporation, 55 Old Bedford Road, Lincoln, MA 01773.

C. Compact Flash Replacement

1. Orient the compact flash by locating the red arrow. This indicates which edge of the device slides in first. The compact flash is keyed, so it will only slide in one way. Look for two small indentations on opposite edges of the device. They should be on the side of the compact flash that faces the front of the unit.
2. Slide the 530-00117-000 Rev 00 compact flash into the slot.
3. Ensure the compact flash is fully seated.
4. Replace the compact flash cover.
5. Secure cover with the nuts.

D. Label Placement

1. Apply TSO label directly below the existing Serial Number tag on the back of the unit.
2. Be sure to install it such that it does not obstruct the existing serial number tag.

E. Re-install and Verification.

1. Re-install the unit in the aircraft and apply power to the unit.
2. The green LED control lights behind all the front panel controls will light up.
3. After the initial power up, the software will load and go through several checks. During this startup sequence the screen will display the text "Initializing-Please Wait...".
4. Verify that the software version number is 5.3.0.
 - a. If software version is not 5.3.0, please call Avidyne Tech Support at 888-723-7592
5. The startup sequence is finished when the text "Press any bezel key to Continue..." is displayed.

Note: Avidyne does not recommend shutting OFF the EX5000C during start up.

Perform the System Setup and Checkout procedures in the Installation manual (p/n 600-00073, Rev 04), to reconfigure the system. Use the setup values recorded in step 3A1 of this service bulletin.

Return the original compact flash to Avidyne.

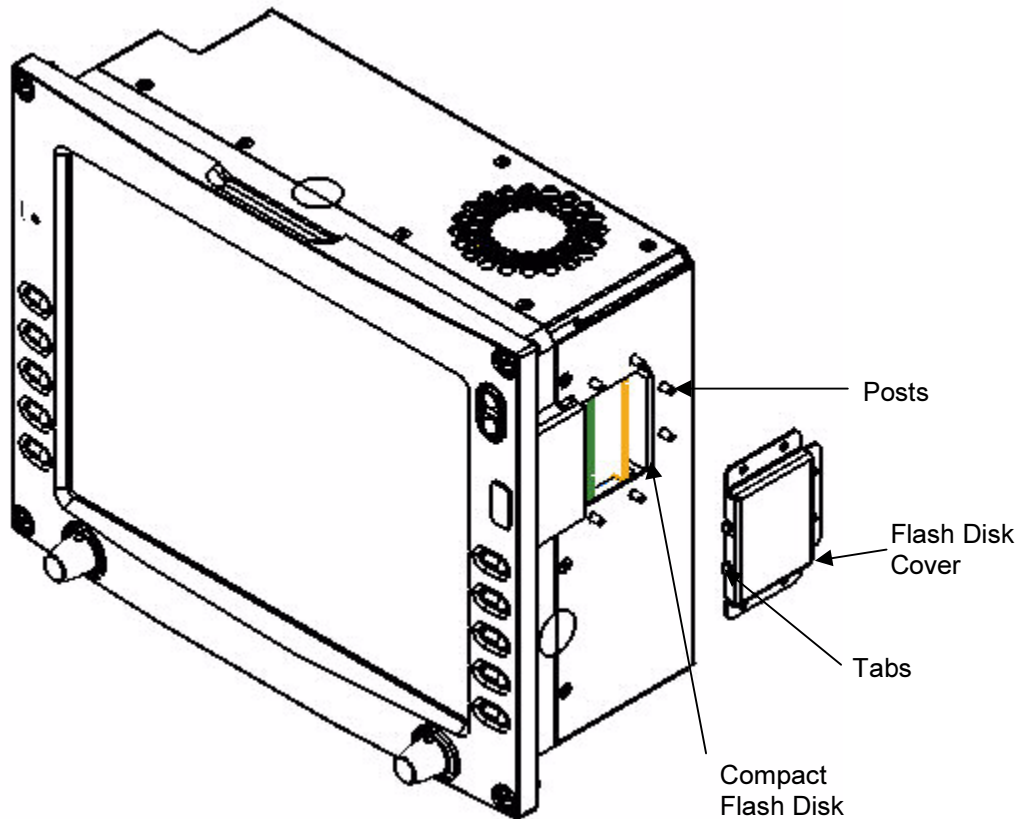

Figure 1: EX5000C with Compact Flash Cover



SERVICE BULLETIN

Service Bulletin #: SB03

Title: Engine Instrument Software Update.

1. Planning Information

A. Effectivity/Compatibility

This Service Bulletin applies to all Avidyne EX5000C's, with the following software part number:

Part Number	Rev.	Software Level
530-00112-000	00	Release 5.2.0
530-00112-000	01	Release 5.2.1
530-00112-000	02	Release 5.2.2

The software part number, revision and software level are displayed on the EX5000C screen during the startup sequence, above the text "Initializing-Please Wait...".

B. Concurrent Requirements

None

C. Reason

A change in the software has been made to provide Engine Instrument display functionality

D. Description

This modification consists of:

- 1) Removing the current compact flash and replacing it with the upgraded compact flash, while the EX5000C is on the bench.
- 2) Application of an additional label that contains additional TSO references.

E. Compliance

This is an optional functionality upgrade that may be installed at the operator's convenience. The installation should reference the appropriate installation of the EX5000C engine instrument per STC SA00143BO and SA00152BO.

F. Approval

No portion of this service bulletin is FAA approved.



SERVICE BULLETIN

G. Manpower

Removal and replacement of the compact flash and should take approximately 10 minutes.
Placement of an the additional label should take approximately 30 seconds.

H. Weight and Balance

No change.

I. Electrical Load Data

Not changed.

J. Software Accomplishment

See paragraph 1C Reasons for change.

K. Reference

Installation manual p/n 600-00073

L. Publications Affected

None

2. Material - Cost and Availability

Cost: Contact Avidyne at 1-888-AVIDYNE.

Availability: Contact Avidyne at 1-888-AVIDYNE and ask for p/n 530-00117-000 Rev 00 compact flash.

This modification may be performed by an authorized Cirrus Service Center, or an Avidyne approved service location subject to current terms and conditions.

3. Accomplishment Instructions

A. Removal of the EX5000C from the aircraft.

1. Access Maintenance Setup pages and record setup values.
2. Remove radio rack interior trim cap.
3. Loosen the 4 Dzus fasteners that hold the unit to the cockpit panel.
4. Pull the unit out approximately 8".
5. Disconnect the cable.



SERVICE BULLETIN

B. Compact Flash Removal

This procedure should be performed on the bench. Ensure NO power is applied to the unit. Refer to Figure 1.

1. Remove the Flash cover by unscrewing the 6 nuts and lifting the cover off the posts.
2. Remove the 530-00112-000 Rev XX (See effectivity/compatibility) compact flash by pulling it from the connector and sliding it out (as shown in Figure 1).
3. Record the serial number of the EX5000C on the removed compact flash and return it to Avidyne Corporation, 55 Old Bedford Road, Lincoln, MA 01773.

C. Compact Flash Replacement

1. Orient the compact flash by locating the red arrow. This indicates which edge of the device slides in first. The compact flash is keyed, so it will only slide in one way. Look for two small indentations on opposite edges of the device. They should be on the side of the compact flash that faces the front of the unit.
2. Slide the 530-00117-000 Rev 00 compact flash into the slot.
3. Ensure the compact flash is fully seated.
4. Replace the compact flash cover.
5. Secure cover with the nuts.

D. Label Placement

1. Apply TSO label directly below the existing Serial Number tag on the back of the unit.
2. Be sure to install it such that it does not obstruct the existing serial number tag.

E. Re-install and Verification.

1. Re-install the unit in the aircraft and apply power to the unit.
2. The green LED control lights behind all the front panel controls will light up.
3. After the initial power up, the software will load and go through several checks. During this startup sequence the screen will display the text "Initializing-Please Wait...".
4. Verify that the software version number is 5.3.0.
 - a. If software version is not 5.3.0, please call Avidyne Tech Support at 888-723-7592
5. The startup sequence is finished when the text "Press any bezel key to Continue..." is displayed.

Note: Avidyne does not recommend shutting OFF the EX5000C during start up.

Perform the System Setup and Checkout procedures in the Installation manual (p/n 600-00073, Rev 04), to reconfigure the system. Use the setup values recorded in step 3A1 of this service bulletin.

Return the original compact flash to Avidyne.

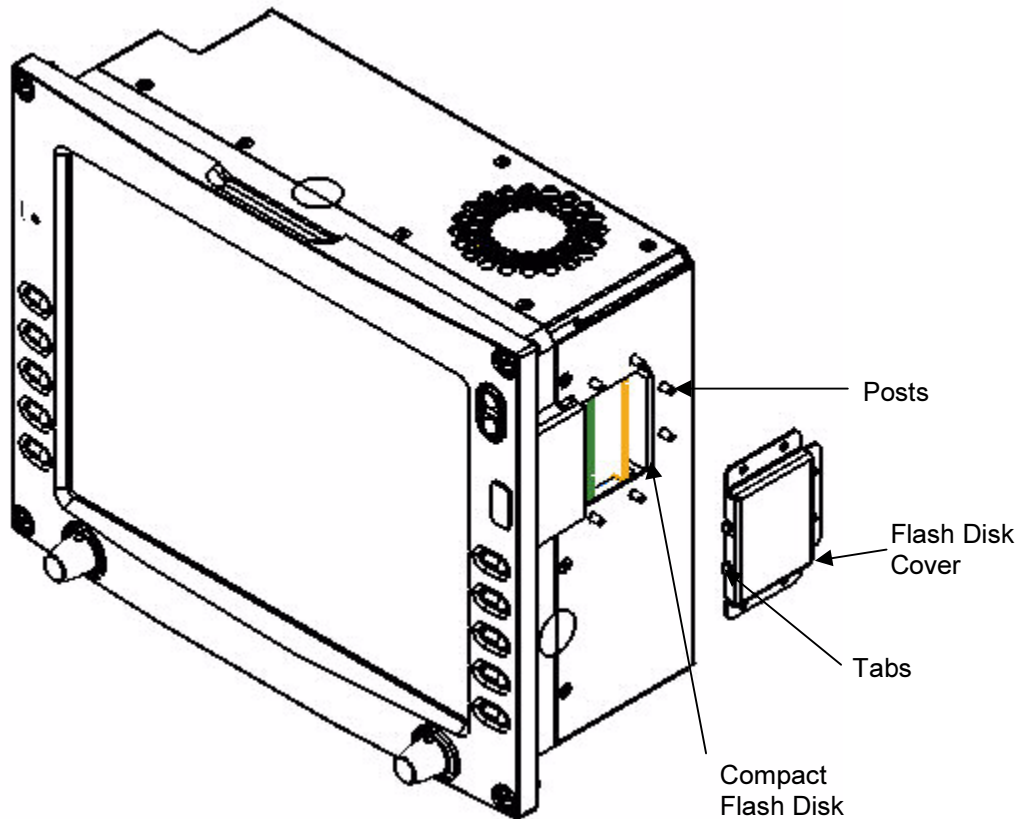

Figure 1: EX5000C with Compact Flash Cover